

This document is the property of Nian-Yeong Corporation and is delivered on the express condition that it is not to be disclosed, reproduced or used, in whole or in part, for manufacture or sale by anyone other than Nian-Yeong Corporation without its prior consent, and that no right is granted to disclose or to use any information in this document.

# CUSTOMER DRAWING

REV.	DESCRIPTION	APPROVED BY	DATE	ECN NO.
A	RELEASE	Fido Weng	22/05/09'	
B	CHANGE HOUSING MATERIAL	Emily Suen	05/06/12'	ECN12012
C	CHANGE METAL CAP PLATING	Emily Suen	14/09/12'	ECN12023

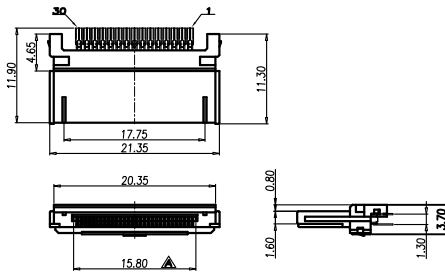
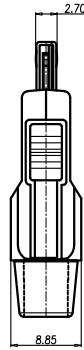
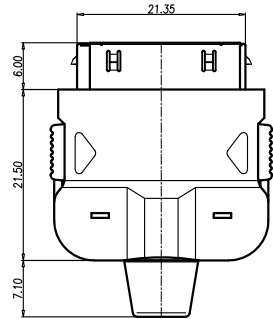
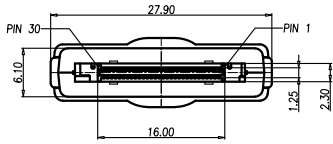

膠芯+PIN

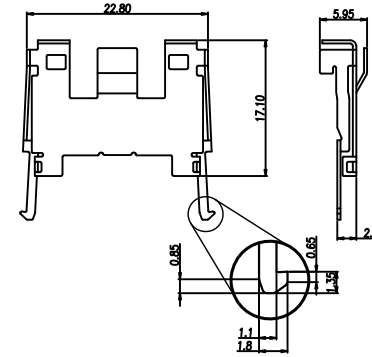

金屬上蓋

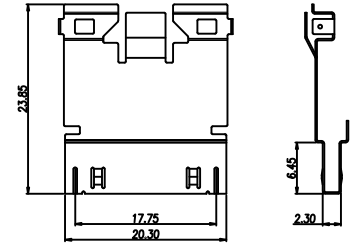

金屬下蓋

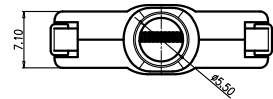

成品

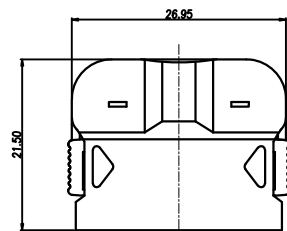

塑膠上蓋

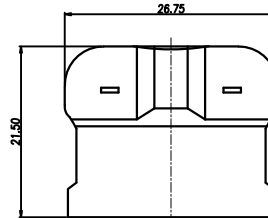

塑膠下蓋

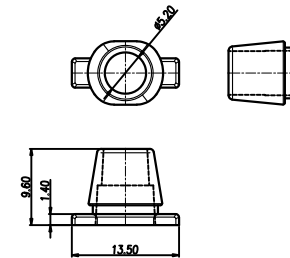

SR

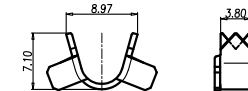

線夾

**NOTE:**

- MATERIAL:
  - CONTACT: BRONZE.
  - METAL UP-CAP: STAINLESS STEEL.
  - METAL DOWN-CAP: STAINLESS STEEL.
  - CABLE FIXED: BRASS.
  - HOUSING: LCP
  - PLASTIC UP-CAP: PC.
  - PLASTIC DOWN-CAP: PC.
  - SR: PVC.
- PLATING:
  - CONTACT: CONTACT AREA : 5u" MIN. GOLD PLATED  
SOLDER AREA : SEE TABLE A  
UNDER PLATE : NICKEL
  - CABLE FIXED: TIN 50u"
  - METAL UP-CAP: NICKEL 60u"
  - METAL DOWN-CAP: SATIN NICKEL PLATING.

TABLE A

PC-30M2-18	iPOD 30PIN (M)	BLACK	BRIGHT TIN 60u"
PC-30M2-05	iPOD 14/30 PIN (M)	BLACK	GOLD FLASH
PC-30M2-02	iPOD 30PIN (M)	WHITE	GOLD FLASH
PC-30M2-01	iPOD 30PIN (M)	BLACK	GOLD FLASH
P/N	DESCRIPTION	HOUSING	SOLDER AREA FINISH

DRAWN	Yeh Chou	APP'D	Emily Suen	UNIT	mm	TOLERANCE			TITLE	iPOD 30(M)線夾裝配式			SHEET	1/3
CHK'D	Emily Suen	SCALE	1:1	ANGULA	±1°	PART NO.			SEE TABLE A	DWG NO.	QC2127	VERSION	C	

This document is the property of Nian-Yeong Corporation and is delivered on the express condition that it is not to be disclosed, reproduced or used, in whole or in part, for manufacture or sale by anyone other than Nian-Yeong Corporation without its prior consent, and that no right is granted to disclose or to use any information in this document.

### CUSTOMER DRAWING

REV.	DESCRIPTION	APPROVED BY	DATE	ECN NO.
A	RELEASE	Fido Weng	22/05/09'	
B	CHANGE HOUSING MATERIAL	Emily Suen	05/06/12'	ECN12012
C	CHANGE METAL CAP PLATING	Emily Suen	14/09/12'	ECN12023

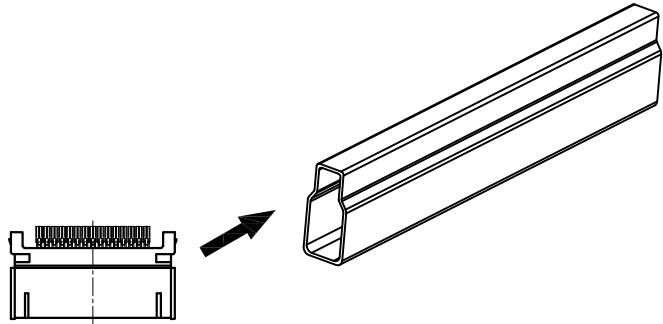

PUT THE CONNECTOR IN THE TUBE  
15PCS/1TUBE

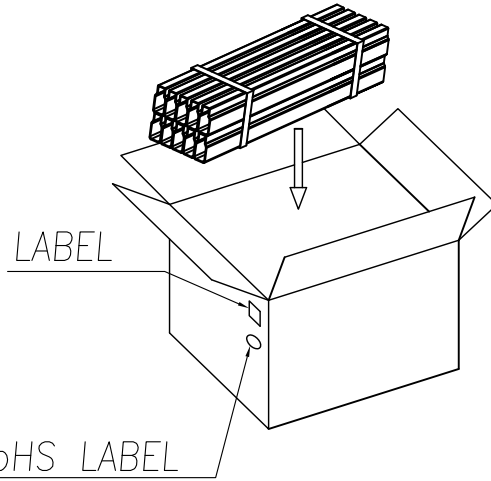

PUT STACK TUBES INTO THE CARTON BOXES

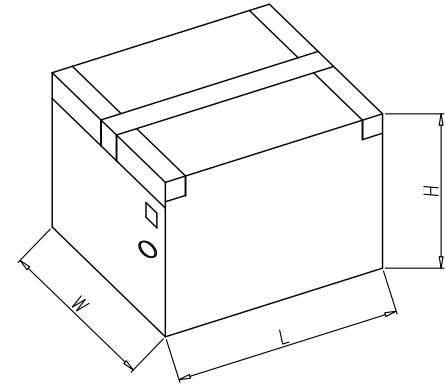

PASTE THE TAPE LABEL AND  
RoHS LABEL  
ON CARTON BOXES AS DRAWING

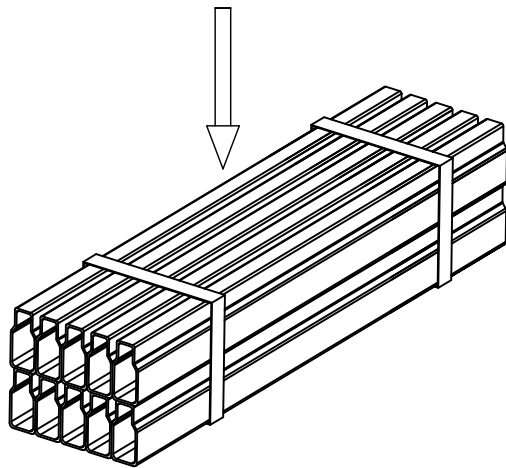

PUT 10 TUBES ON STACK AND PASTE  
THE TAPE AS DRAWING

### PACKING MATERIAL

PM NAME	PM NO.	DIM.(LxWxH)/mm	QUANTITY
TUBE	PK-MU0004	365X6.8X15	600
CARTON BOXES	CB-003	415X297X242	1

### PACKING QUANTITY

PCS/TU	PCS/STACK	PCS/CB
15PCS/TU	150PCS/STACK	9000PCS/CB

DRAWN	Yeh Chou	APP'D	Emily Suen	UNIT	mm	TOLERANCE			TITLE	iPOD 30(M) <del>CONNECTOR</del>			SHEET
CHK'D	Emily Suen			SCALE	1:1	.x ±0.20 .xx ±0.10 .xxx ±0.05 .xxxx ±0.03 ANGULA ±1°			PART NO.	SEE TABLE A	DWG NO.	QC2127	2 3 VERSION C

NIAN YEONG ENTERPRISE  
年永實業有限公司

This document is the property of Nian-Yeong Corporation and is delivered on the express condition that it is not to be disclosed, reproduced or used, in whole or in part, for manufacture or sale by anyone other than Nian-Yeong Corporation without its prior consent, and that no right is granted to disclose or to use any information in this document.

# CUSTOMER DRAWING

REV.	DESCRIPTION	APPVL. BY	DATE	ECN NO.
A	RELEASE	Fido Weng	22/05/09'	
B	CHANGE HOUSING MATERIAL	Emily Suen	05/06/12'	ECN12012
C	CHANGE METAL CAP PLATING	Emily Suen	14/09/12'	ECN12023

## 步驟一:

- 將成品放入PE袋
- 每個包裝好的PE袋以熱封機熱封  
數量SEE TABLE A

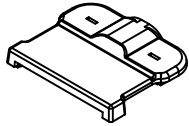

ON-PC0183

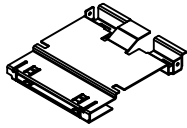

OY-PC0399



ON-PC0184

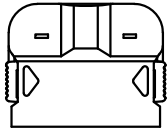

ON-PC0182

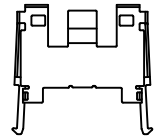

OY-PC0380



OY-PC0379

## 步驟二:

- 一個紙箱可以裝10個PE袋
- 每箱數量SEE TABLE A
- 將PE袋放紙箱中,後封箱.

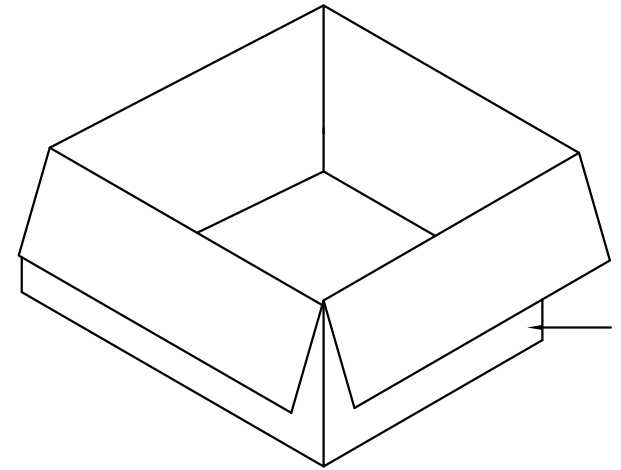

紙箱

## PACKING MATERIAL : CARTON

PRODUCT	1 PACKAGE
ON-PC0184	1000 pcs
ON-PC0183	1000 pcs
ON-PC0182	1000 pcs
OY-PC0399	500 pcs
OY-PC0380	500 pcs
OY-PC0379	1000 pcs

## 步驟三:

- 用膠帶將紙箱封實.
- 將標籤貼於紙箱上.

標籤處

ITEM NO:	
QTY:	PGS
N.W.:	KG
G.W.:	KG
MEAS:	

C/NO.:
--------

CARTON SIZE	
34*23.5*22.5	
N.W. : 2.50kgs	G.W. : 3.50kgs

DRAW	Yeh Chou	APPVL	Emily Suen	UNIT	mm	TOLERANCE
CHECK	Emily Suen			SCALE	1:1	.x ±0.20 .xx ±0.10 .xxx ±0.05 .xxxx ±0.03 ANGULA ±1°

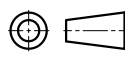

**NIAN YEONG ENTERPRISE**  
年永實業有限公司

TITLE	iPOD 30(M)線端裝配式			SHEET	3/3
PART NO.	SEE TABLE A	DWG NO.	QC2127	VERSION	C