

This document is the property of Nian-Yeong Corporation and is delivered on the express condition that it is not to be disclosed, reproduced or used, in whole or in part, for manufacture or sale by anyone other than Nian-Yeong Corporation without its prior consent, and that no right is granted to disclose or to use any information in this document.

CUSTOMER DRAWING

| REV. | DESCRIPTION | APPROVED BY | DATE | ECN NO. |
|------|-------------|-------------|-----------|---------|
| A | RELEASE | Fido Weng | 05/03/10* | |
| B | | | | |
| C | | | | |

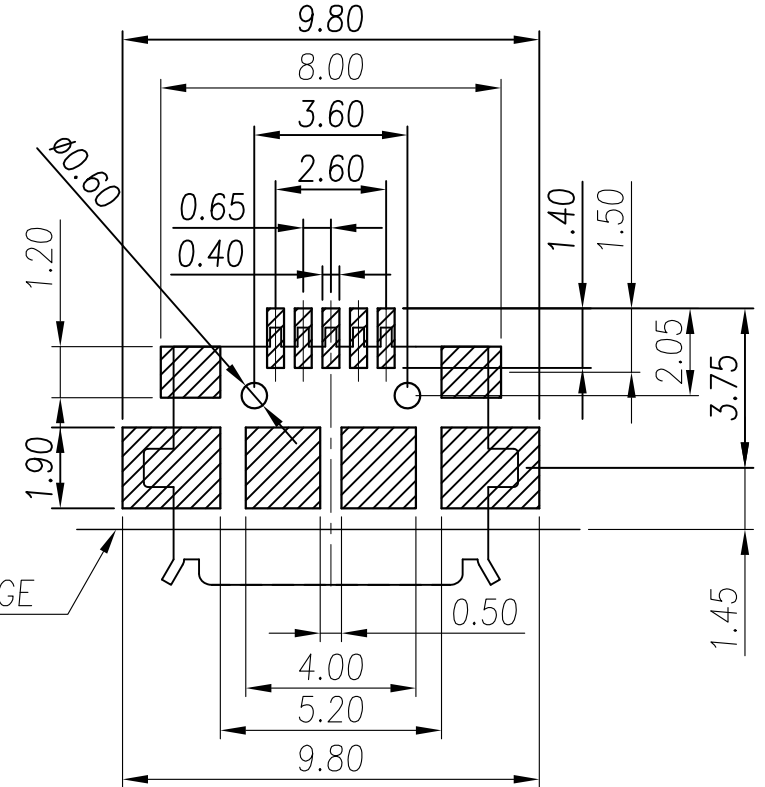
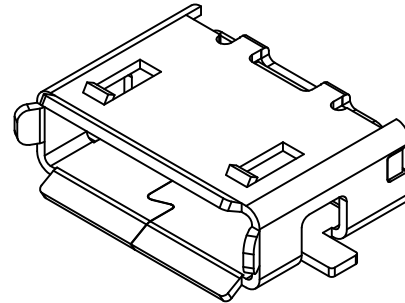
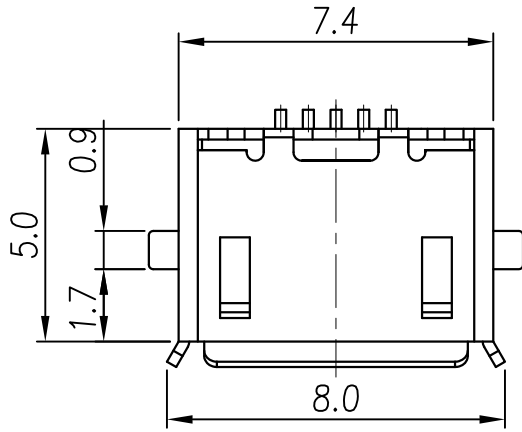

RECOMMEND P.C.B LAYOUT
(TOP VIEW)

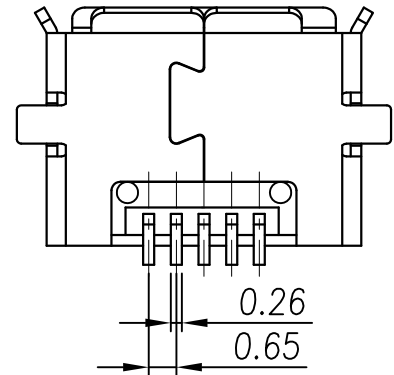
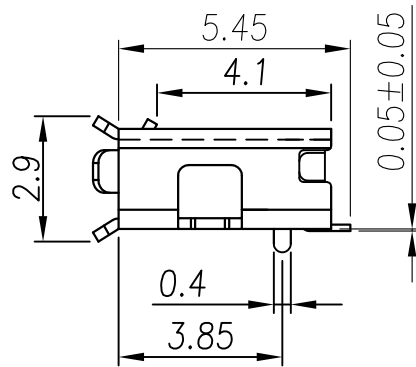
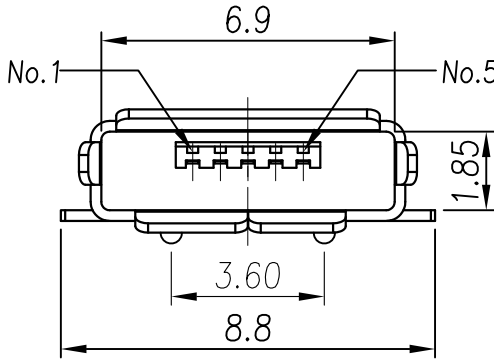

- MATERIAL :
 - 1-1. HOUSING : LCP UL94V-0 ; COLOR : BLACK
 - 1-2. PIN : PHOSPHOR BRONZE.
 - 1-3. SHELL : STAINLESS STEEL
- FINISH :
 - 2-1. CONTACT AREA : SEE TABLE A
SOLDER AREA : GOLD FLASH
UNDERPLATED : NICKEL
 - 2-2. SHELL : MATTE TIN OVER ALL

TABLE A

| | | | |
|---|------------|-----------|----------------|
| 1 | MU-05F4-35 | GOLD 15u" | MATTE TIN 60u" |
| 2 | MU-05F4-34 | GOLD 10u" | MATTE TIN 60u" |
| | P/N | PLATING | CONTACT AREA |
| | | | SHELL |

| DRAWN | Jen Xie | APPEND | Fido Weng | UNIT | mm | TOLERANCE | NIAN YEONG ENTERPRISE 年永實業有限公司 | | TITLE | MICRO USB 5PIN(F) AB TYPE SHELL | | | SHEET |
|--------|------------|--------|-----------|-------|-----|--|-----------------------------------|--|----------|---------------------------------|---------|--------|------------------|
| CHOKED | Emily Suen | | | SCALE | 1:1 | .x ±0.20 .xx ±0.10 .xxx ±0.05 .xxxx ±0.03 ANGULA ±1° | | | PART NO. | SEE TABLE A | DWG NO. | QC3040 | 1/2 VERSION A |

This document is the property of Nian-Yeong Corporation and is delivered on the express condition that it is not to be disclosed, reproduced or used, in whole or in part, for manufacture or sale by anyone other than Nian-Yeong Corporation without its prior consent, and that no right is granted to disclose or to use any information in this document.

CUSTOMER DRAWING

| REV. | DESCRIPTION | APPROVED BY | DATE | ECN NO. |
|------|-------------|-------------|-----------|----------|
| A | RELEASE | Fido Weng | 22/12/08* | ECN10097 |
| B | | | | |
| C | | | | |

STEP1:

- 1.Pack finished products into a package tray in the same direction.
- 2.The packing way as shown in the following drawing.
- 3.A package tray has 1500 pcs.

STEP2:

- 1.The carton contains 10 package trays.
- 2.1500 pcs per tray; 15000 pcs per carton.
- 3.Put package trays into a waterproof bag and pack before sealing.

STEP3:

- 1.Seal the box with tape.
- 2.Paste the carton with label.

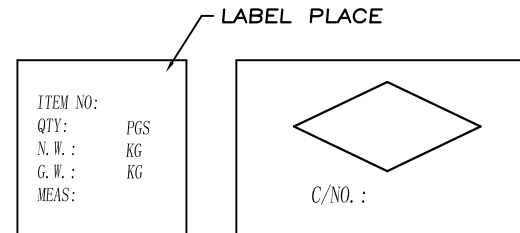
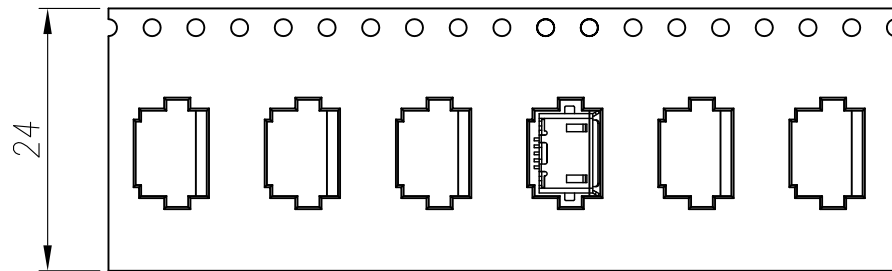
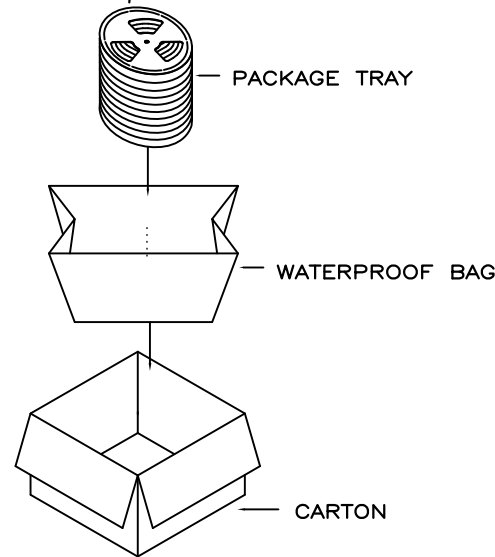
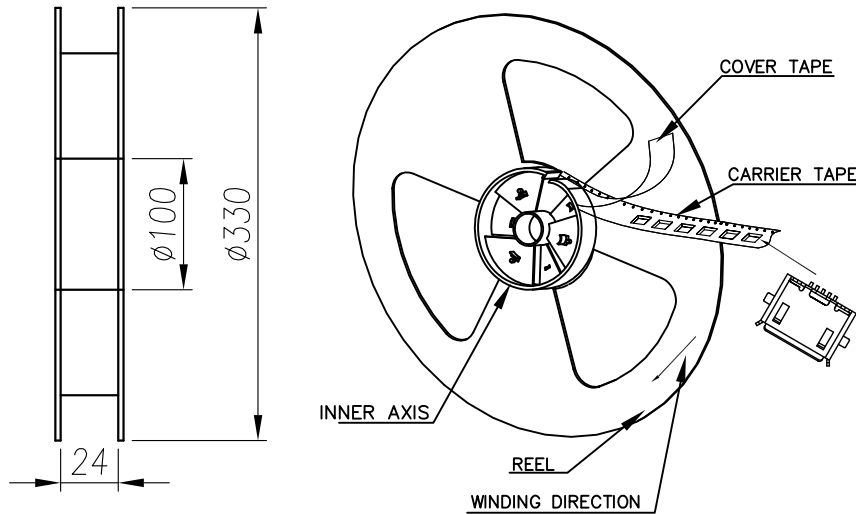

| DRAWN | Jen Xie | APP'D | Fido Weng | UNIT | mm | TOLERANCE | .x ±0.20 .xx ±0.10 .xxx ±0.05 .xxxx ±0.03 ANGULA ±1° | TITLE | MICRO USB 5PIN(F) AB TYPE SHELL | | | SHEET | 2/2 |
|---|------------|-------|-----------|-------|-----|-----------|--|----------|---------------------------------|---------|--------|---------|-----|
| CHK'D | Emily Suen | SCALE | 1:1 | SCALE | 1:1 | ANGULA | ±1° | PART NO. | PK-1-MU-05F4-14 | DWG NO. | QC3040 | VERSION | A |
|  NIAN YEONG ENTERPRISE 年永實業有限公司 | | | | | | | | | | | | | |