

This document is the property of Nian-Yeong Corporation and is delivered on the express condition that it is not to be disclosed, reproduced or used, in whole or in part, for manufacture or sale by anyone other than Nian-Yeong Corporation without its prior consent, and that no right is granted to disclose or to use any information in this document.

CUSTOMER DRAWING

REV.	DESCRIPTION	APPROVED BY	DATE	ECN NO.
A	RELEASE	Ku Chou	02/08/18*	
B	CHANGE CLAMP RING MATERIAL	Ku Chou	30/10/18*	
C				

TABLE A

P/N	CLAMP RING MATERIAL
RJ-08M2-01-01	PA66
RJ-08M2-03-01	PBT+PC, UL94V-0(F1)

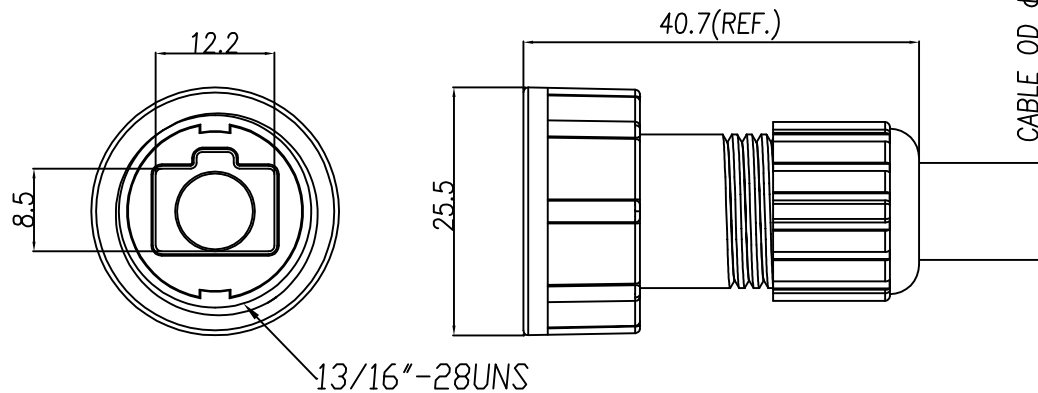
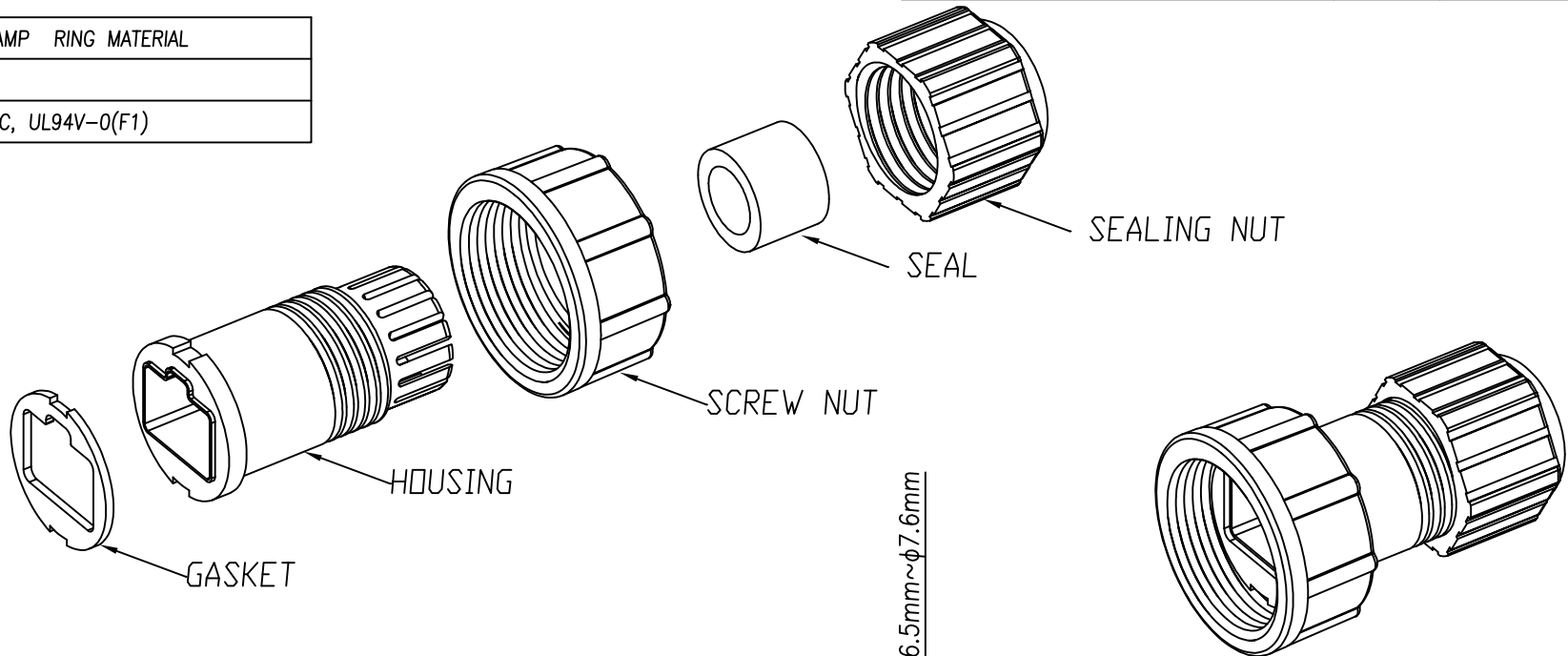

1. MATERIAL :
- 1-1. GASKET : SILICONE
 - 1-2. CLAMP RING : SEE TABLE A
 - 1-3. SCREW NUT : PA66
 - 1-4. SEAL : SILICONE
 - 1-5. SEALING NUT : PA66

DRAWN	Emily Suen	APP'D	Ku Chou	UNIT	mm	TOLERANCE				TITLE	13/16"-28UNS RJ45 ASSEMBLY TYPE			SHEET	
CHK'D	Ku Chou	SCALE	1:1	ANGULAR	±1°	PART NO.				SEE TABLE A	DWG NO.	QC8655	VERSION	B	

NIAN YEONG ENTERPRISE
年永實業有限公司