

This document is the property of Nian-Yeong Corporation and is delivered on the express condition that it is not to be disclosed, reproduced or used, in whole or in part, for manufacture or sale by anyone other than Nian-Yeong Corporation without its prior consent, and that no right is granted to disclose or to use any information in this document.

CUSTOMER DRAWING

REV.	DESCRIPTION	APPROVED BY	DATE	ECN NO.
△A				
△B				
△C				

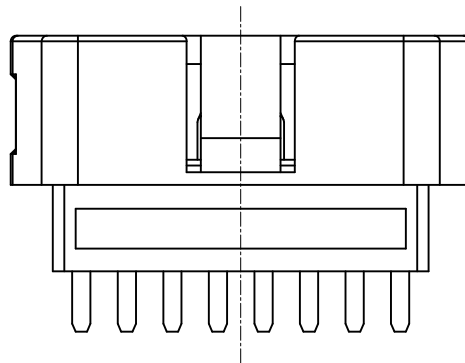
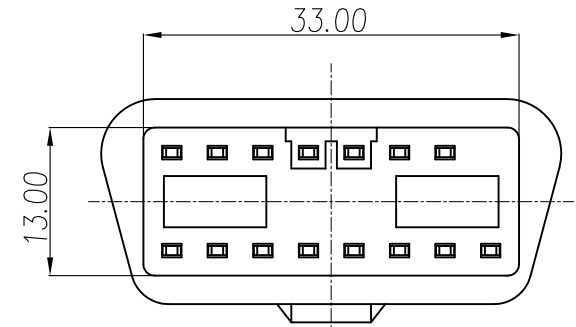
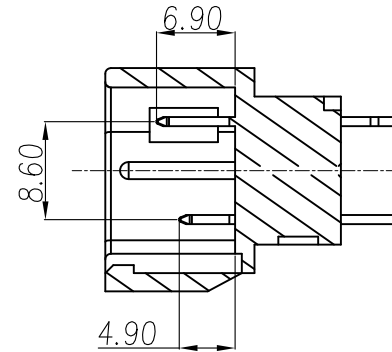
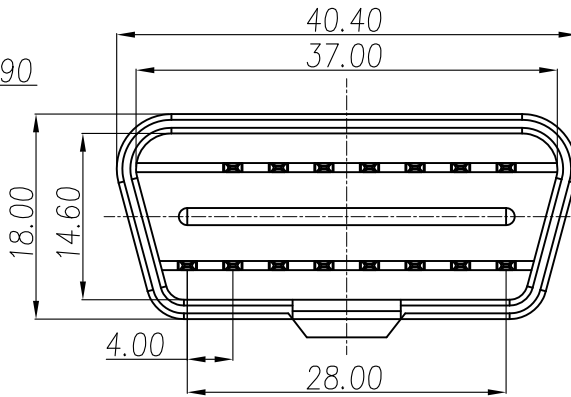
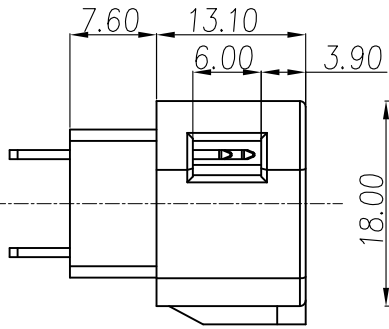
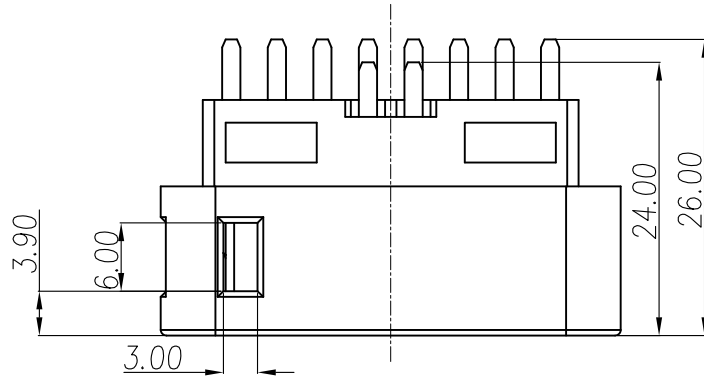

- MATERIAL :
 - HOUSING : NYLON66+ GF 15% UL94V-0 ; COLOR : BLACK.
 - CONTACT : BRASS
- FINISH :
 - CONTACT : BRIGHT TIN 80u"
- Environmental :
 - Operation Temperature : -40°C~85°C

DRAWN	Yeh Chou	APP'D	Emily Suen	UNIT	mm	TOLERANCE			TITLE	OBD2 15PIN (M) 成型式 單隔板			SHEET	1
CHK'D	Emily Suen			SCALE	1:1	.x ±0.20 .xx ±0.10 .xxx ±0.05 .xxxx ±0.03 ANGULA ±1°			PART NO.	OBD2-15M1-01-11	DWG NO.	QC7852	VERSION	A

NIAN YEONG ENTERPRISE
年永實業有限公司