

This document is the property of Nian-Yeong Corporation and is delivered on the express condition that it is not to be disclosed, reproduced or used, in whole or in part, for manufacture or sale by anyone other than Nian-Yeong Corporation without its prior consent, and that no right is granted to disclose or to use any information in this document.

CUSTOMER DRAWING

REV.	DESCRIPTION	APPROVED BY	DATE	ECN NO.
A	RELEASE	Emily Suen	25/10/11*	
B				
C				
D				

1. MATERIAL :

- 1-1. HOUSING : PPS UL94V-0
COLOR : BLACK
- 1-2. CONTACT : BRASS
- 1-3. PLUG SHELL : ZINC ALLOY
- 1-4. LOCKING COLLAR : ZINC ALLOY
- 1-5. SPRING1 : STAINLESS STEEL
- 1-6. SPRING2 : STAINLESS STEEL
- 1-7. O-RING 1 : EPDM
- 1-8. BACK SHELL : ZINC ALLOY
- 1-9. SHIELDING : PHOSPHOR BRONZE
- 1-10. O-RING 2 : EPDM
- 1-11. CLAMP : BRASS
- 1-12. O-RING 3 : NBR ; COLOR : BLACK
- 1-13. STRAIN RELIEF COLLAR : NYLON66 UL94V-0 ; COLOR : WHITE
- 1-14. TIGHTENING COLLAR : PPS ; COLOR : BROWN

TABLE A

CONTACT ARRANGEMENT(FRONT VIEW)	
WP-03M2-28	WP-06M2-19

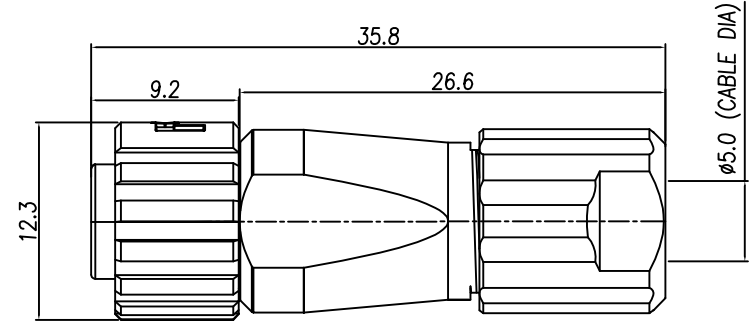

2. FINISH :

- 2-1. CONTACT : GOLD FLASH
- 2-2. PLUG SHELL : NICKEL
- 2-3. LOCKING COLLAR : NICKEL
- 2-4. BACK SHELL : NICKEL
- 2-5. SHIELDING : NICKEL
- 2-6. CLAMP : NICKEL

3. ELECTRICAL SPECIFICATION :

- 3-1. Rated current : 3PIN 5A ; 6PIN 2A
- 3-2. Rated voltage : 3PIN 125V AC / 175V DC ;
6PIN 30V AC / 42V DC
- 3-3. Water proof : IP67

4. Environmental :

- 4-1. Operation Temperature : -25°C~85°C

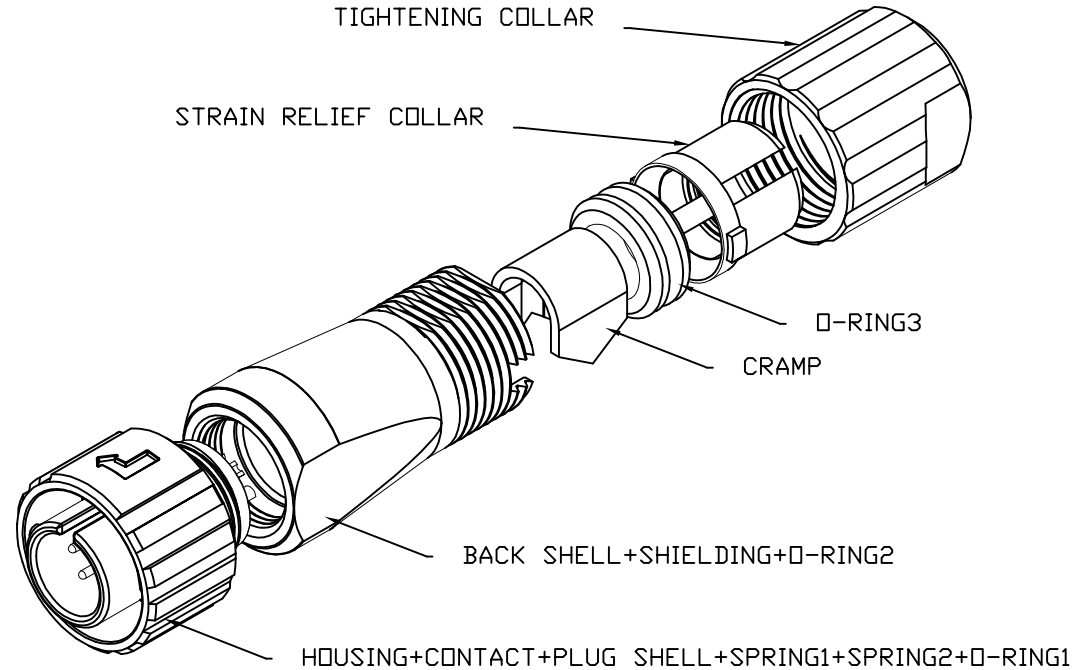

DRAWN	Mark Kao	APPVL	Ku Chou	UNIT	mm	TOLERANCE				TITLE	WP (M) 连接器 (PLUG-LF07 TYPE)			SHEET	1/2
CHK'D	Emily Suen			SCALE	1:1	.x ±0.20 .xx ±0.10 .xxx ±0.05 .xxxx ±0.03 ANGULA ±1°				PART NO.	SEE TABLE A	DWG NO.	QC5713	VERSION	A

NIAN YEONG ENTERPRISE
年永實業有限公司

This document is the property of Nian-Yeong Corporation and is delivered on the express condition that it is not to be disclosed, reproduced or used, in whole or in part, for manufacture or sale by anyone other than Nian-Yeong Corporation without its prior consent, and that no right is granted to disclose or to use any information in this document.

CUSTOMER DRAWING

REV.	DESCRIPTION	APPROVED BY	DATE	ECN NO.
A	RELEASE	Emily Suen	22/08/11'	
B				
C				
D				

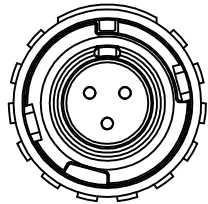
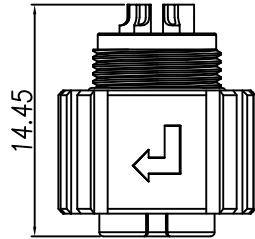
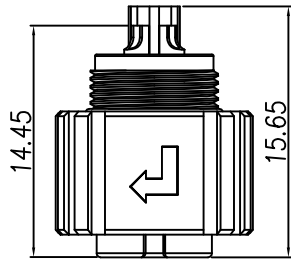

3P

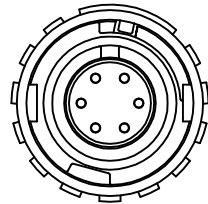

6P

HOUSING+CONTACT+PLUG SHELL+SPRING1+SPRING2+O-RING1

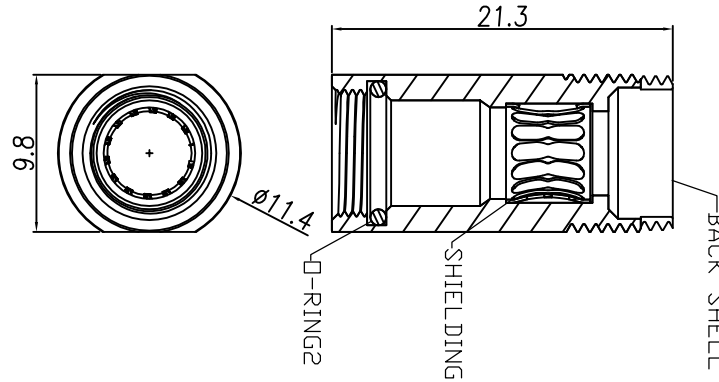

BACK SHELL+SHIELDING+O-RING2

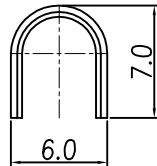
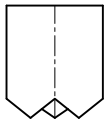

CRAMP

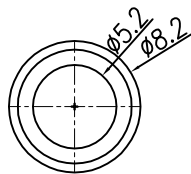

O-RING3

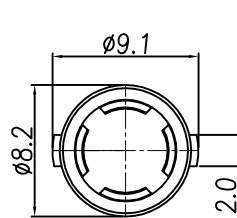

STRAIN RELIEF COLLAR

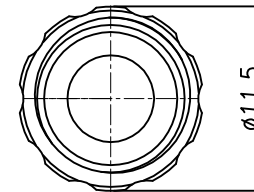
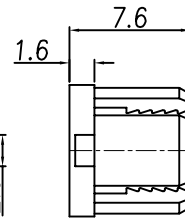

TIGHTENING COLLAR

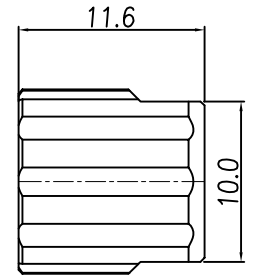

DRAWN	Mark Kao	APPVL	Ku Chou	UNIT	mm	TOLERANCE		TITLE	WP (M) 连接器 (PLUG-LF07 TYPE)			SHEET
CHK'D	Emily Suen			SCALE	1:1	.x ±0.20 .xx ±0.10 .xxx ±0.05 .xxxx ±0.03 ANGULA ±1°		PART NO.	SEE TABLE A	DWG NO.	QC5713	2/2
NIAN YEONG ENTERPRISE 年永實業有限公司												VERSION
												A