

This document is the property of Nian-Yeong Corporation and is delivered on the express condition that it is not to be disclosed, reproduced or used, in whole or in part, for manufacture or sale by anyone other than Nian-Yeong Corporation without its prior consent, and that no right is granted to disclose or to use any information in this document.

CUSTOMER DRAWING

REV.	DESCRIPTION	APPVL. BY	DATE	ECN NO.
△	Del Table A	Fido Weng	20/03/09*	ECN-09032
△	ADD P/N	Fido Weng	12/02/14*	
△	更改油封材質	KU	26/06/18*	

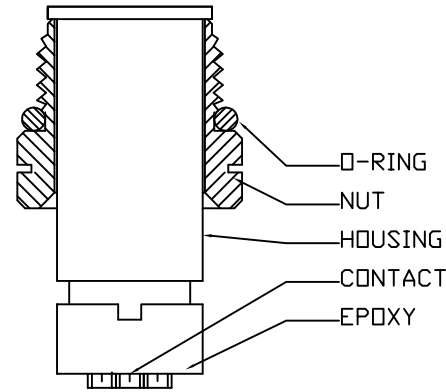
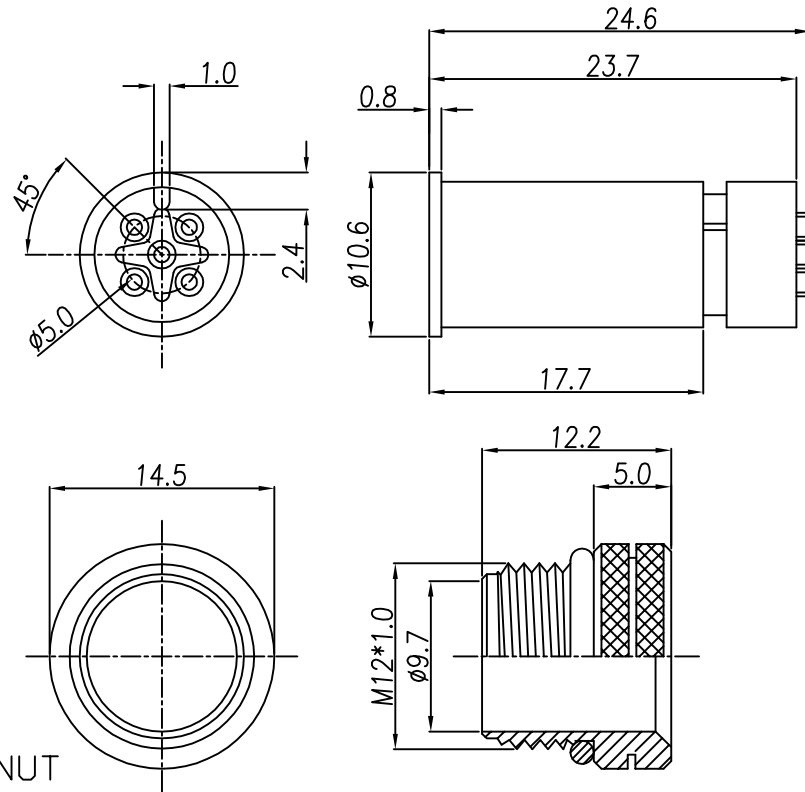

ASS'Y

TABLE A

5PIN	4PIN
WP-05M2-103-11 WPM12-05M2-01-11 WPM12-05M2-02 WP-05M2-60	WP-04M2-121-11 WP-04M2-15 WPM12-04M2-02 WP-04M2-249-11
3PIN	3PIN
WP-03M2-64-11 WPM12-03M2-02 WP-03M2-127-11	WP-03M2-25 WP-03M2-65-11 WP-03M2-131-11
2PIN	2PIN
WP-02M2-02	WP-02M2-35-11

- MATERIAL :
 - HOUSING : PBT UL94V-0 ; COLOR : BLACK.
 - CONTACT : BRASS
 - NUT : SEE TABLE A
 - O-RING : SEE TABLE A ; COLOR : SEE TABLE A
- FINISH :
 - CONTACT : SEE TABLE A
 - NUT : SEE TABLE A
- ELECTRICAL SPECIFICATION :
 - Rated current : 4A
 - Rated voltage : 2~4PIN 250V ; 5PIN 60V
 - Water proof : IP67
- Environmental :
 - Operation Temperature : -40℃~85℃

WP-04M2-249-11	STAINLESS STEEL 316	—	10u" GOLD PLATED	EPDM(BLACK)
WP-03M2-131-11	STAINLESS STEEL 316	—	10u" GOLD PLATED	EPDM(BLACK)
WP-03M2-127-11	STAINLESS STEEL 316	—	10u" GOLD PLATED	EPDM(BLACK)
WP-05M2-103-11	BRASS	NICKEL PLATED	GOLD FLASH PLATED	NBR(BLACK)
WP-05M2-60	BRASS	NICKEL PLATED	GOLD FLASH PLATED	EPDM(BLACK)
WP-04M2-121-11	BRASS	NICKEL PLATED	GOLD FLASH PLATED	EPDM(BLACK)
WP-03M2-64-11	BRASS	NICKEL PLATED	GOLD FLASH PLATED	EPDM(BLACK)
WP-03M2-65-11	BRASS	NICKEL PLATED	GOLD FLASH PLATED	EPDM(BLACK)
WPM12-05M2-01-11	BRASS	NICKEL PLATED	10u" GOLD PLATED	NBR(BLACK)
WPM12-05M2-02	BRASS	NICKEL PLATED	10u" GOLD PLATED	EPDM(BLACK)
WP-04M2-15	BRASS	NICKEL PLATED	10u" GOLD PLATED	SILICONE(GREEN)
WPM12-04M2-02	BRASS	NICKEL PLATED	10u" GOLD PLATED	EPDM(BLACK)
WPM12-03M2-02	BRASS	NICKEL PLATED	10u" GOLD PLATED	EPDM(BLACK)
WP-03M2-25	BRASS	NICKEL PLATED	10u" GOLD PLATED	EPDM(BLACK)
WP-02M2-02	BRASS	NICKEL PLATED	10u" GOLD PLATED	EPDM(BLACK)
WP-02M2-35-11	BRASS	NICKEL PLATED	10u" GOLD PLATED	EPDM(BLACK)
PART No.	MATERIAL(NUT)	FINISH(NUT)	FINISH(CONTACT)	O-RING(COLOR)

DRAW	Ku Chou	APPVL	Fido Weng	UNIT	mm	TOLERANCE	TITLE		SHEET
CHECK	Emily Suen			SCALE	1:1	.x ±0.20 .xx ±0.10 .xxx ±0.05 .xxxx ±0.03 ANGULA ±1°	防水頭 M12 (M)線端		1
							PART NO.	SEE TABLE A	VERSION
							DWG NO.	QC1467	F

NIAN YEONG ENTERPRISE
年永實業有限公司